

Features:

- Switch 10 ports
- 8 PoE ports 10/100 Mb/s (data and power supply)
- 2 port 10/100 Mb/s (UP LINK)
- 30 W for each PoE port, supports devices complaint with the IEEE802.3af/at (**PoE+**) standard
- Supports auto-learning and auto-aging of MAC addresses (1K size)
- LED indication
- The PSD520175 52 V DC/1,75 A/90 W max. power supply desktop type included
- Additional assembly elements
- warranty – 2 year from the production date

Example of use.

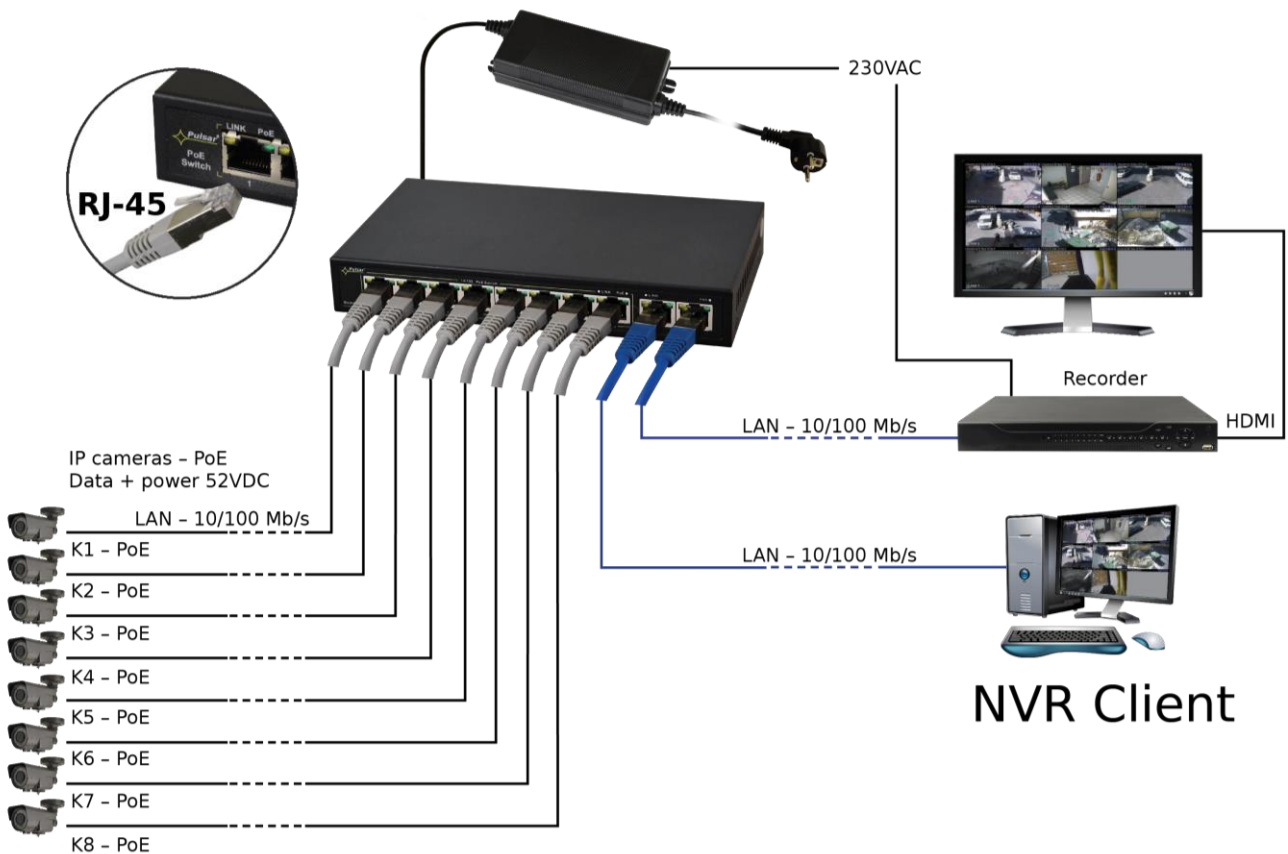

1. Technical description

1.1. General description.

S108-90W is a 10-ports PoE switch designed to supply IP cameras operating in IEEE 802.3af/at standard. Automatic detection of any devices powered in the PoE/PoE+ standard is enabled at the 1 – 8 ports of the switch. The UP LINK ports is used for connection of another network device via RJ45 connector. The LEDs at the front panel indicate the operation status (description in the table below).

The PoE technology ensures a network connection and reduces installation costs by eliminating the need to supply a separate power cable for each device. This method allows supplying other network devices, such as IP phone, wireless access point or router.

1.2 Block diagram.

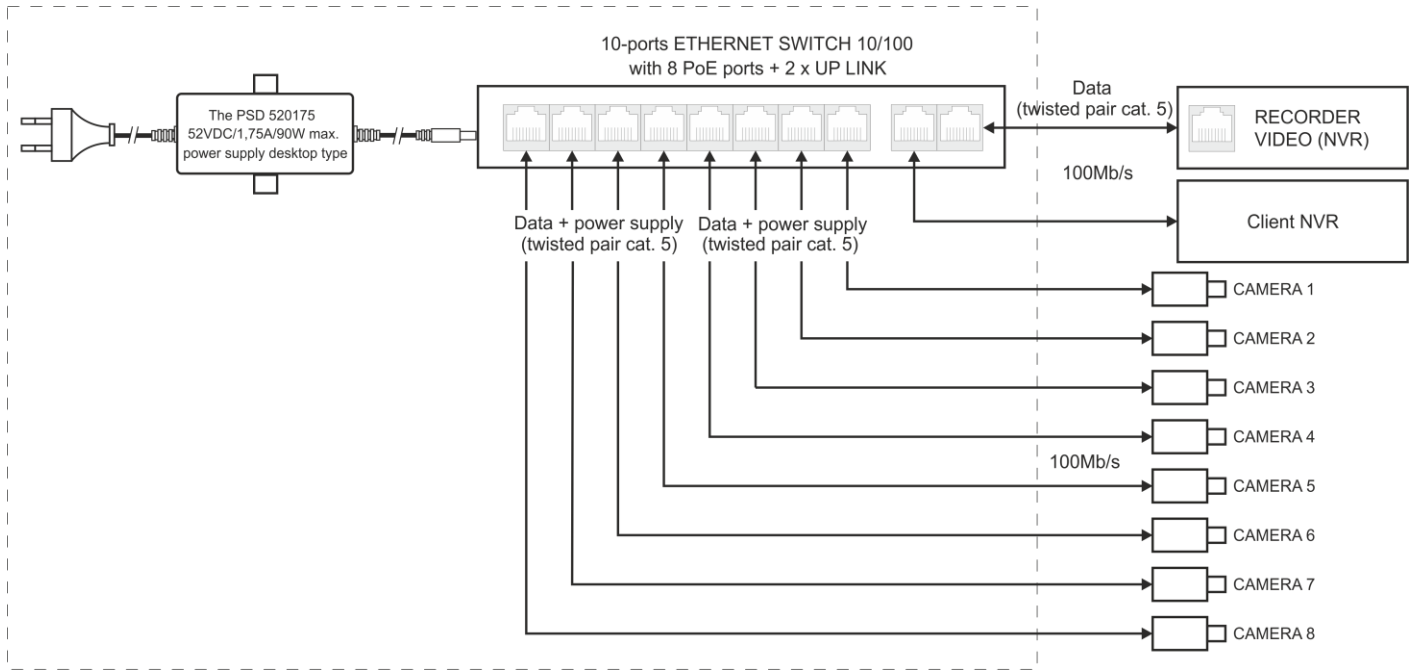

Fig. 1. Block diagram.

1.3 Description of components and connectors.

Table 1. (See Fig. 2)

Component No. (Fig. 2)	Description
[1]	8 x PoE ports (1÷8)
[2]	2 x UP LINK port
[3]	Power Socket of the DC
[4]	Additional assembly elements

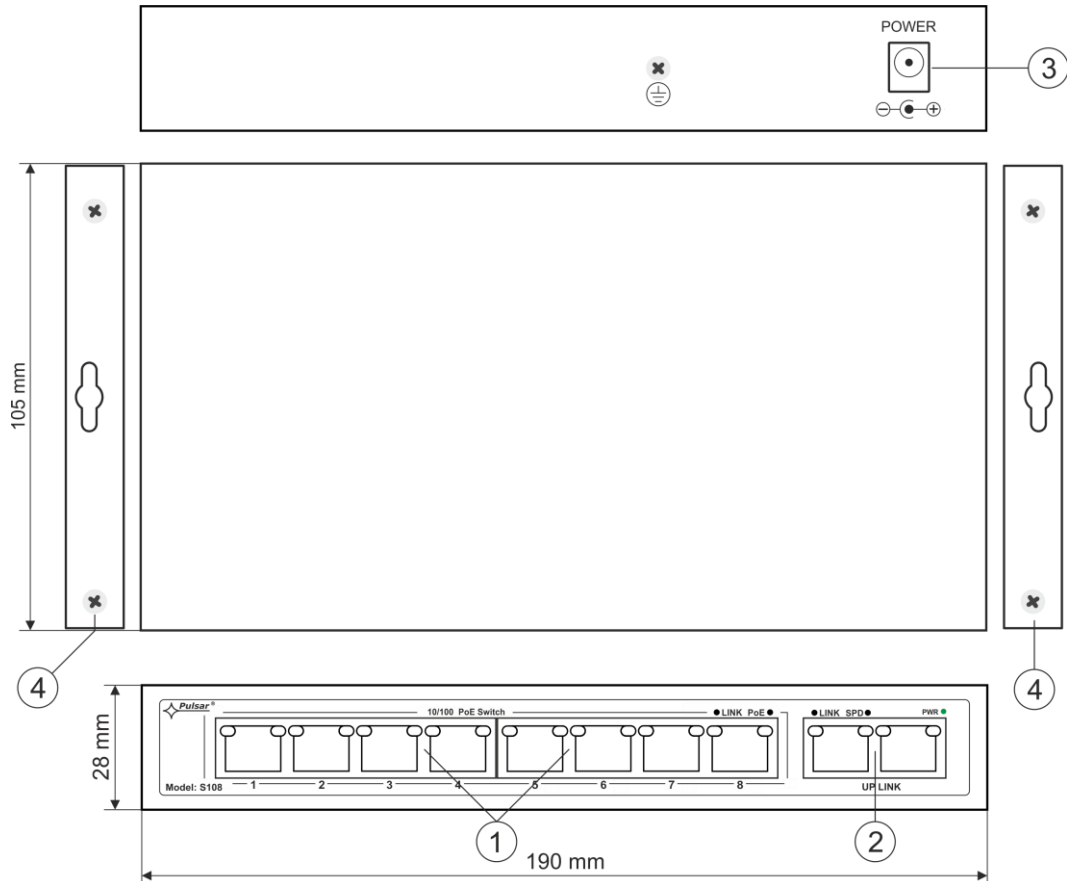

Fig. 2. The view of the switch.

1.4 Technical parameters

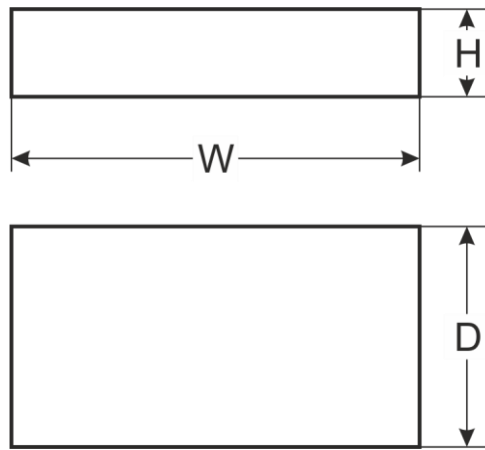

Table 2.

Ports	10 ports 10/100 Mb/s (8 x PoE + 2 x UP LINK) with connection speed auto-negotiation and MDI/MDIX Auto Cross)
PoE power supply	IEEE 802.3af/at (1+8 ports), 52 V DC / 30 W at each port *
Protocols, Standards	IEEE802.3, 802.3u, 802.3x CSMA/CD, TCP/IP
Bandwidth	1,6 Gbps
Transmission method	Store-and-Forward
Optical indication of operation	Switch power supply; Link/Act; PoE Status
Power supply	~100-240 V; 50/60 Hz; 2 A the PSD 520175 52 V DC/1,75 A/90 W max. power supply desktop type
Operating conditions	temperature -10 °C ÷ 40 °C, relative humidity 5 % - 90 %, no condensation
Dimensions	W=190, H=28, D=105 [+/- 2 mm]
Additional equipment	plate to be fixed surface
Gross/Net weight	1,2 / 1,4 kg
Protection class EN 60950-1:2007	II (second)
Storage temperature	-20 °C ÷ 60 °C
Declarations	CE

* The given value of 30 W per port is the maximum value. The total power consumption should not exceed 80 W.

2. Installation

2.1. Requirements

The unit should be mounted in confined spaces, in accordance with the 2nd environmental class, with normal relative humidity (RH=90 % maximum, without condensation) and temperature from -10 °C to +40 °C. Ensure the free flow of air around the unit. The PSU shall work in a vertical position that guarantees sufficient convective air-flow through ventilating holes of the enclosure.

The switch load balance should be done before installation. The given value of 30 W per port is the maximum value referring to a single output. The total power consumption should not exceed 80 W. The increased demand for power is particularly evident in the case of cameras with heaters or infrared illuminators - when launching these features, the power consumption increases rapidly, which may adversely affect the operation of the switch. As the device is designed for a continuous operation and is not equipped with a power-switch, therefore an appropriate overload protection in the power supply circuit should be provided. The electrical system shall be made in accordance with applicable standards and regulations.

2.2. Installation procedure



1. Connect switch to the PSD520175 52 V DC power supply unit desktop type.
2. Connect the power supply to the 230 V socket.
3. Connect the camera wires to the RJ45 connectors (connectors PoE).
4. Check the optical indication of switch operation (see Table 3).

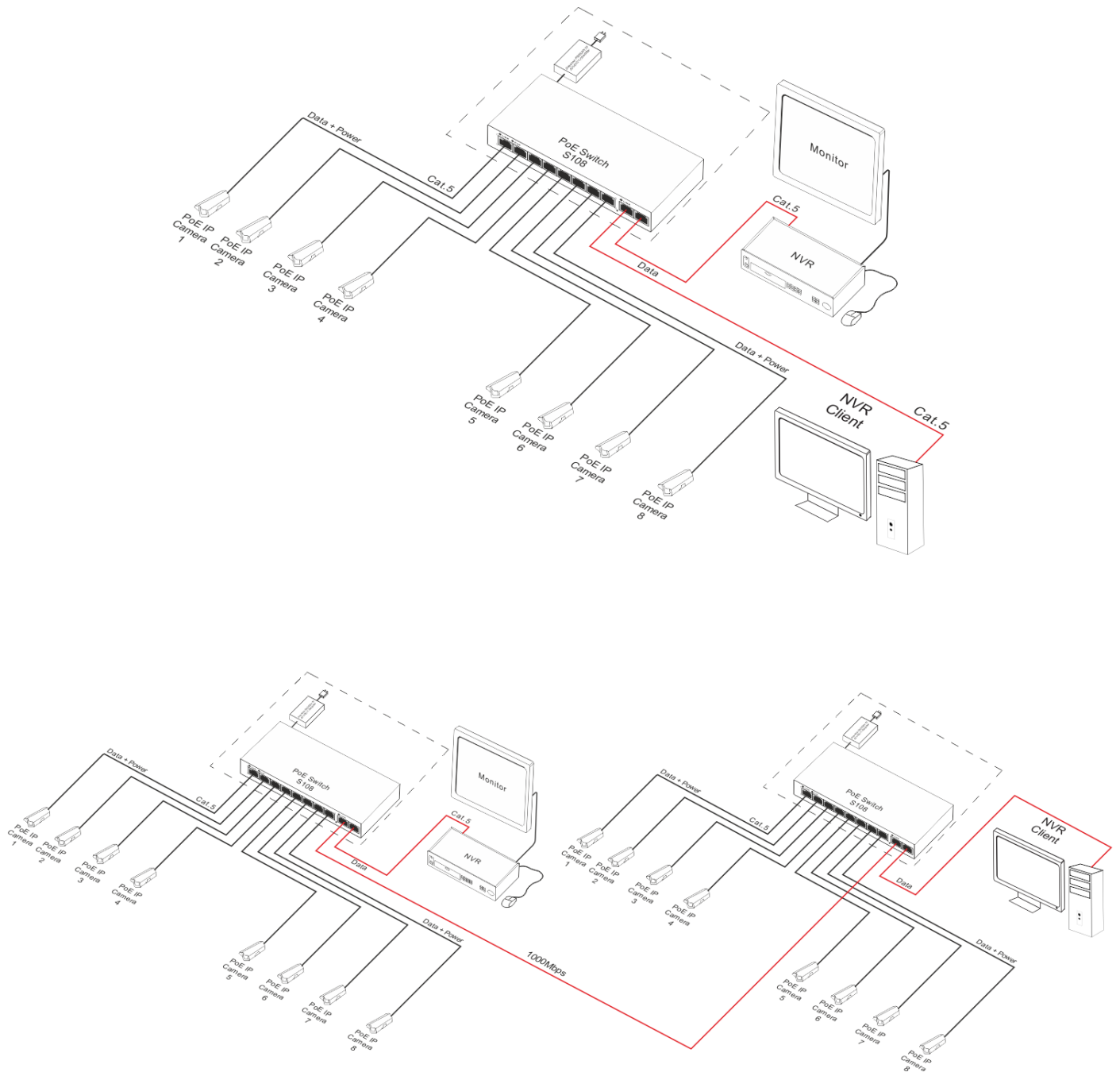

Connection schemes



3. Operation indication.

Table 3. Operation indication

OPTICAL INDICATION AT THE PoE PORTS (1+8)		
GREEN LED LIGHT (PoE) Indication of the PoE power supply at the RJ45 ports		OFF - no power supply at the RJ45 port (the device is not connected or not compliant with the IEEE802.3af/at standard) ON – power supply at the RJ45 port Blinking – short-circuit or output overload
YELLOW LED LIGHT (LINK) The connection status of LAN devices 10/100 Mb/s and data transmission		OFF - no connection ON - the device is connected 10/100 Mb/s Blinking – data transmission

OPTICAL INDICATION AT THE UP LINK PORTS		
GREEN LED LIGHT		Applies only to the right side port: No light (OFF) - No supply voltage of the switch ON - the switch is powered, correct operation
YELLOW LED LIGHT (LINK) The connection status of LAN devices 10/100 Mb/s and data transmission		OFF - no data transmission ON - the device is connected 10/100 Mb/s Blinking – data transmission



WEEE LABEL

Waste electrical and electronic equipment must not be disposed of with normal household waste. According to the European Union WEEE Directive, waste electrical and electronic equipment should be disposed of separately from normal household waste.



Pulsar sp. j.
 Siedlec 150, 32-744 Łapczyca, Poland
 Tel. (+48) 14-610-19-40, Fax. (+48) 14-610-19-50
 e-mail: biuro@pulsar.pl, sales@pulsar.pl
 http:// www.pulsar.pl, www.zasilacze.pl